

# CALJAN BELTRACK, TYPE F

## TELESCOPIC BELT CONVEYORS

### Cost-effective

A belt speed of 1 m/s doubles capacity compared to standard conveyor solutions and more than quadruples through-put compared to manual loading.

### Short ROI

A high volume can be handled by just a few doors, reducing building costs. Fast belt speeds and telescopic action give very short turn-around times at each door.

### Ergonomic and flexible

The ergonomic design with control panels on both sides provides for two operators, utilizing the high belt speed.



## WITH TWO OPERATORS WORKING THE SAME BELT, TURN-AROUND TIMES ARE GREATLY REDUCED

Caljan BeltTrack, type F, combines speed with ergonomic operation. The gently rounded profile and dual control panels allow two operators to work in unison to load the vehicle. The head of the conveyor can be placed at the appropriate height and extension by either operator. Capacity is increased, without causing stress.



**Quality**  
Identical control panels on each side give both operators access to emergency stop, speed control and joystick.



**Safety**  
Caljan BeltTrack, type F, is part of our SAFETrack program – quite simply the safest telescopic conveyors on the market, complying with European Safety and EMC requirements for equipment used to handle unit loads: EN619



**Service**  
A well-established service network, ensures that qualified technicians can be on hand as required.



## Description

Caljan BeltTrack, type F, can be floor-mounted, dedicated to a particular door, or fitted with a rail carriage so that it can move parallel to the doors in the loading zone, servicing whichever door is appropriate.

## Design

When designing Caljan BeltTrack, type F, our objective has been to provide increased loading capacity without pressing equipment and personnel beyond their limits. All parts of this rugged machine are able to operate at high speed and able to withstand the harsh environment of the loading zone. All moving parts are protected to meet the latest safety regulations. The uniformity of the telescopic movement is ensured by ball bearings and roller chains on both sides, providing strength and correct extension throughout the machines lifetime. The telescopic extension and retraction is powered by a gear motor to ensure smooth and safe movement. The machine is fully guarded on the underside for optimal safety.

## Dimensions

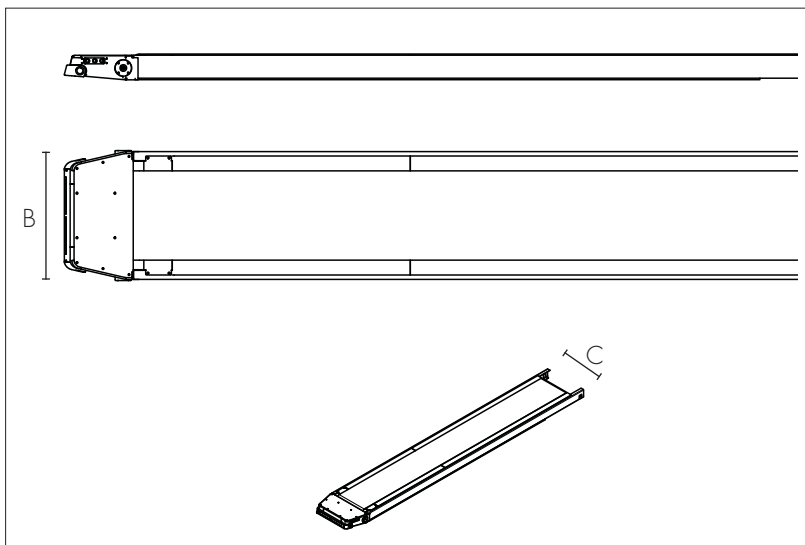

Type	Contracted	Extend-ability	Total Length	Height	Width [B]	Belt width [C]
4 section Caljan BeltTrack, type F						
CF4H-7.9	7.900	15.300	23.200	750	C+384	600/800

All dimensions are stated in mm.

## Technical Data

Retracted length:	7.9 metres (+75 mm safety strip)
Extendability:	15.3 metres
Height:	750 mm
Belt width:	Standard 600 mm, 800 mm on request
Belt type:	HQ-multiply PVC belt
Belt speed:	2-speed 0.5 m/s and 1 m/s
Belt direction:	Loading
Belt drive:	Gear motor controlled by frequency inverter
Telescopic movement:	Gear motor controlled by frequency inverter
Telescopic speed	18 m/min. (0.3 m/s)
Load:	50 kg/m
Power supply:	3 x 400 V AC, 50 Hz
Control:	PLC control system
Control panel:	Joystick, emergency stop and speed selector on both sides

Auxilliary equipment:	Safety strip and light at front, incl. down-light
Joystick:	Push the joystick to extend the conveyor. Pressure must be maintained to ensure safe operation. Pulling the joystick back for 5 seconds retracts the boom 1 meter. To completely retract the boom, maintain pressure on the joystick. Changing joystick direction will stop this operation
Colour:	Standard RAL 3020. Other RAL colours available on request

Optional features:	800 mm belt width, portal tube light, side guards, hydraulic movement and more. Please ask for further details
--------------------	--



www.caljanritehite.com

**Denmark**  
Caljan Rite-Hite ApS  
Ved Milepaelen 6-8  
DK-8361 Hasselager  
Aarhus  
Tel. +45 87 38 78 00  
Fax +45 87 38 78 01

**Germany**  
Caljan Rite-Hite GmbH  
Industriestraße 7  
D-65439 Flörsheim  
Tel. +49 6145 93490  
Fax +49 6145 934930

**UK**  
Caljan Rite-Hite Ltd  
Moorbridge Road  
Bingham Industrial Estate  
Nottingham NG13 8GG  
Tel. +44 (0) 1949 838 850  
Fax +44 (0) 1949 836 953

**France**  
Caljan Rite-Hite S.A.R.L.  
8, Rue Georges Besse  
ZAC du Fossé Pâtié  
F-78330 Fontenay-le-Fleury  
Tél +33 1 30 07 12 37  
Fax +33 1 30 23 05 69

**Benelux**  
Caljan Rite-Hite BV  
Engelenburgstraat 57  
7391 AM Twello  
Tel. +31 (571) 270 444  
Fax +31 (571) 270 555

**USA**  
Caljan Rite-Hite Inc.  
3600 E. 45th Avenue  
Denver, CO 80216  
Tel. +1 303 321 3600  
Fax +1 303 321 6767